

The Americans with Disabilities Act

What's New

What Organizations that Serve Survivors of Domestic and Sexual Violence Need to Know

Kathy Gips
Institute for Human Centered Design
200 Portland St.
Boston, MA 02114
617-695-0085 voice/tty
kgips@humancentereddesign.org



Ten ADA Centers

Funded by the National Institute on Disability and Rehabilitation Research

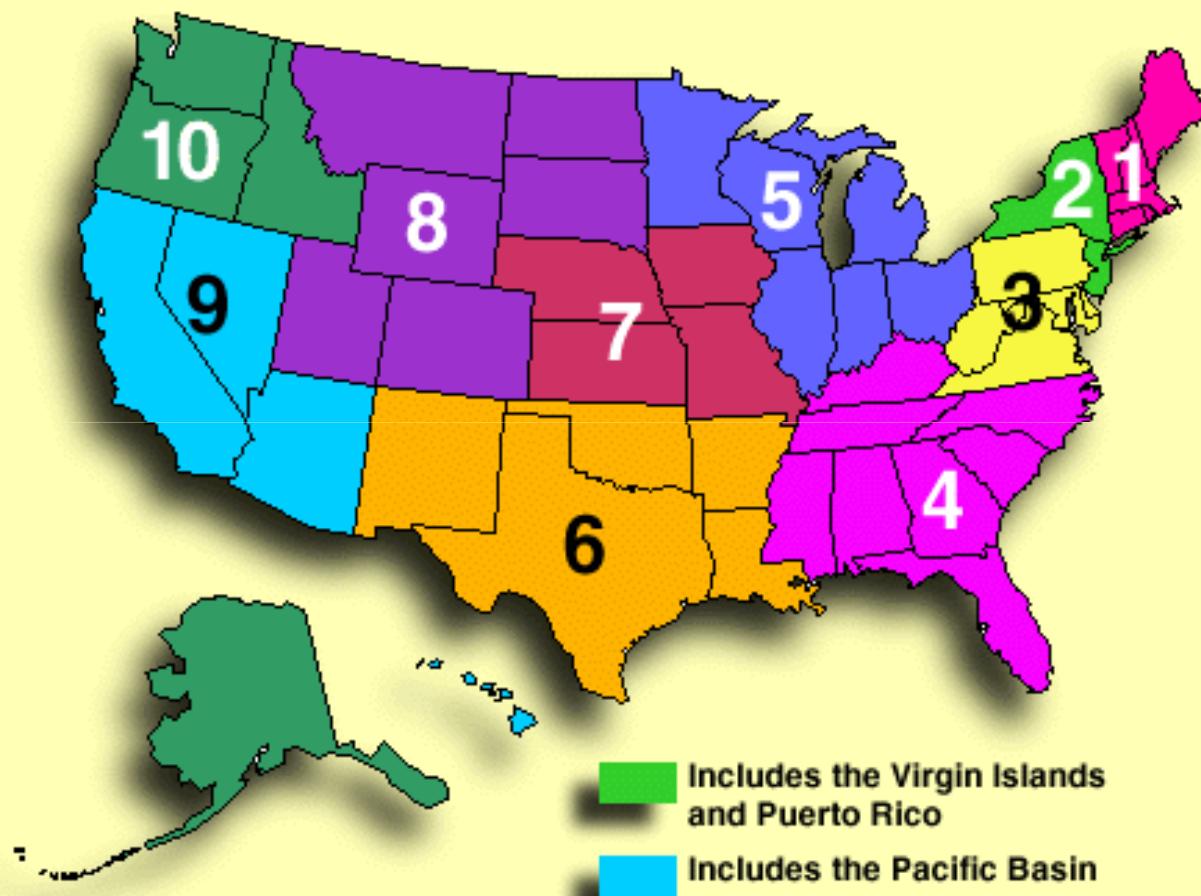

1-800-949-4232 voice/tty
www.adata.org

Agenda

- ADA & Laws Overview
- Definition of Disability – Who's in, Who's out
- Administrative requirements
- General non-discrimination requirements
- Ensuring effective communication
- Facility accessibility
- Employment

Section 504 of the Rehabilitation Act of 1973 as amended

...No otherwise qualified individual with a disability in the United States...shall, solely by reason of her or his disability, be excluded from the participation in, be denied the benefits of, or be subjected to discrimination under any program or activity **receiving federal financial assistance** or under any program or activity conducted by any executive agency or by the United States Postal Service.

Americans with Disabilities Act (ADA) of 1990, as amended

- Provide a clear and comprehensive national mandate for the elimination of discrimination against individuals with disabilities

Structure of the ADA

Title I: Employment

Title II: State and Local Governments

Title III: Private Entities Operating Public
Accommodations or Commercial
Facilities

Title IV: Telecommunications Relay Service
(TRS)

Title V: Miscellaneous

ADA and Section 504

Definition of Disability – Three Parts

An individual who

- has
 - has a record or history of
 - or
 - is regarded as having
- a physical or mental impairment that substantially limits a major life activity

ADA and Section 504

Examples of major life activities

- caring for oneself
- performing manual tasks
- seeing
- hearing
- eating
- sleeping
- walking
- standing
- lifting
- bending
- speaking
- breathing
- learning
- reading
- concentrating
- thinking
- communicating
- working

More Major Life Activities

Major bodily functions

- Functions of the immune system
- Normal cell growth
- Digestive, bowel, bladder, neurological, brain, respiratory, circulatory, endocrine, and reproductive functions

Substantial Limitation of Major Life Activity

Is major life activity substantially limited?

- Compare with “most people”
- Should not require extensive analysis
- Congress wants broad coverage

Definition of Disability Episodic, in Remission

Episodic impairments or impairments that go into remission are considered disabilities if they substantially limit a major life activity *when active*

Examples: depression, bipolar disorder, Post-Traumatic Stress Disorder, other psychiatric conditions, epilepsy, cancer

Scenario

Ms. A has cerebral palsy.

It takes her about two hours to walk a mile.

She is able to walk with no pain.

Does she have a disability under the ADA?

Scenario

Ms. B is diagnosed with depression.

She'll be fine for months but a few times a year she becomes severely depressed and has difficulty sleeping, taking care of herself and working.

The depression usually lasts a week.

Does she have a disability under the ADA?

Scenario

Ms. C has diabetes.

She regularly tests her blood levels, takes insulin as needed and eats on a schedule. As a result she is fully functioning.

If she didn't do these things she would go into a coma.

Does she have a disability under the ADA?

ADA and Section 504

Definition of Disability – Second Part

An individual who

has

has a record or history of

or

is regarded as having

a physical or mental impairment that substantially limits a major life activity

Scenario

Ms. E has alcoholism.

She has not had a drink in ten years.

When she was an active alcoholic she was unable to work or take care of herself.

Does she have a disability as defined under the ADA?

ADA and Section 504

Definition of Disability – Third Part

An individual who

has

has a record or history of

or

is regarded as having

a physical or mental impairment that substantially limits a major life activity

Scenario

Ms. F has facial scars from a fire that occurred when she was young.

As a result of the scars a therapist refuses to allow her to participate in group therapy because of concerns about other participants' reactions.

Has she been "regarded" as disabled?

Definition of Disability

An individual who

- has
- has a record or history of

or

- is regarded as having
a physical or mental impairment that
substantially limits a major life activity

End of Definition of Disability

ADA Title II & Section 504 Administrative Requirements

1. Notify public, participants, applicants, about compliance & what's accessible
2. Conduct a Self-Evaluation
3. Develop a Transition Plan
4. Adopt a grievance procedure
5. Designate a responsible employee

ADA & Section 504

- General nondiscrimination
- Effective communication
- Facility access
- Employment

Scenario

XYZ program does not allow women to use alcohol or to be under the influence of alcohol when in the shelter.

Ms T informs you that she has alcoholism, is therefore protected by the ADA and will sometimes be inebriated while in the shelter. What is your response?

General Nondiscrimination Requirements

- Ensure an equal opportunity to participate and benefit
- Prohibit exclusion, segregation, and unequal treatment based on disability
- Prohibit eligibility criteria that screen out person with disability unless criteria are necessary

Scenario

Before accepting participants into their program ABC agency asks applicants whether they've been hospitalized in the past year, whether they are taking medication and if so what kind of medication.

Is this allowed under the ADA?

Scenario

After accepting participants into their program ABC agency asks applicants whether they've been hospitalized in the past year, whether they are taking medication and if so what kind of medication.

Is this allowed under the ADA?

Inquiries About Disability, Medical Condition, Medication

Unnecessary inquiries.

The ADA prohibits unnecessary inquiries into the existence of a disability.

(So...okay to make “necessary” inquiries)

Department of Justice *ADA Title II and Title III Technical Assistance Manuals*

General Nondiscrimination Requirements

Reasonable Modifications

When necessary to ensure equal opportunity “reasonable modifications” must be made to policies, practices, procedures

Scenario

Ms. V has cerebral palsy and she uses a dog for stability and to pick up items.

One night while walking home she is sexually assaulted.

The police weren't sure what to do with the dog but they brought Ms. V (and her dog) to the clinic for a sexual assault exam.

The clinic refuses to allow the dog in because of concerns about cleanliness and others' allergies.

What is the clinic's obligation?

ADA Service Animals



ADA Service Animals

Usually dogs, but not always



ADA Service Animals

Usually dogs, but not always



ADA Service Animals

- Any guide dog, signal dog, or other animal individually trained to provide assistance to an individual with a disability
- May ask if it is a service animal required because of a disability
- May ask what service animal provides
- Care/supervision is owner's responsibility
- May exclude if animal's behavior poses a direct threat to health or safety

Note to Shelters and other Residential Settings

- Have obligations under the Fair Housing Amendments Act
- FHAA reasonable accommodation language does not limit to “service animals”



Scenario

Ms. P is coming to your agency for counseling services. She says she has multiple chemical sensitivity and that she needs to meet in a room where no chemicals have been used for three days prior to her visit.

She would like to participate in some of the groups and wants you to assure her that no staff or attendees will be wearing perfume or using fragrances.

What is your organization's obligation?

Make reasonable modifications of policies, practices and procedures

- Be flexible
- Don't say no automatically
- Know whom to discuss the request with
- Consider whether the request would be a “fundamental alteration”

Emergency Preparedness Planning

- May you ask participants if they have a disability and will need assistance in an emergency?
- How to best prepare?

Personal Devices and Services

Not required to provide:

- Personal devices - wheelchairs, eyeglasses, hearing aids
- Services of a personal nature - assistance eating, toileting, or dressing

(Unless they are provided to participants without disabilities)

Scenario

Ms. T has multiple sclerosis. She needs assistance getting on and off the toilet, bathing and dressing. Her husband has been her caregiver. Over the last five years the relationship has gotten abusive.

In order for her to leave her husband and be in the shelter she will need to have someone come in to provide personal care service two or three times a day.

The shelter has a “no visitors” policy.

Does the shelter need to modify this policy?

ADA & Section 504

- ✓ **General nondiscrimination**
 - Effective communication**
 - Facility access**
 - Employment**

The police are told that a Deaf woman witnessed an act of domestic violence and want to interview the woman.

The woman's daughter hears and is fluent in sign language.

ADA regulations suggest a family member is the most appropriate person to provide sign language interpretation in this situation.

True or False?

Effective Communication

Ensure that communication with people with disabilities is as effective as communication with others

Effective Communication

People who

- are blind or visually impaired
- are Deaf or hard of hearing
or
- have a speech disability

Auxiliary Aids and Services

Provide “auxiliary aids and services”

If necessary to ensure effective communication

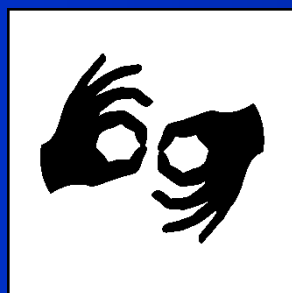

You get a call at 2 am from a man saying his cousin needs to come to the shelter as soon as possible. The man tells you that his cousin is Deaf and requests that either a staff person who uses ASL or a sign language interpreter be present.

You

1. Give the information to your supervisor
2. Give the information to the ADA Coordinator
3. Tell them your organization doesn't provide sign language interpreters
4. Other _____

Auxiliary Aids and Services for Deaf or Hard of Hearing People

- Written notes or typing at keyboard
- Qualified Interpreters
- Computer-aided Real-time Transcription Services (CART)
- Assistive Listening Systems
- Open and Closed Captioning on Videos
- TTYs
- Telephone amplifiers
- Hearing aid compatible telephones

Assistive Listening Devices

Amplify sound for an individual





ALD at Science Center

Note the Sign



Closed or open captioning on videos, etc.



Videos - Closed or Open Captions



Computer Aided Real-time Transcription CART



When using a sign language Interpreter face and look at the Deaf person.



Ensuring effective communication in a group



Woman in brown shirt is Deaf, interpreter is standing

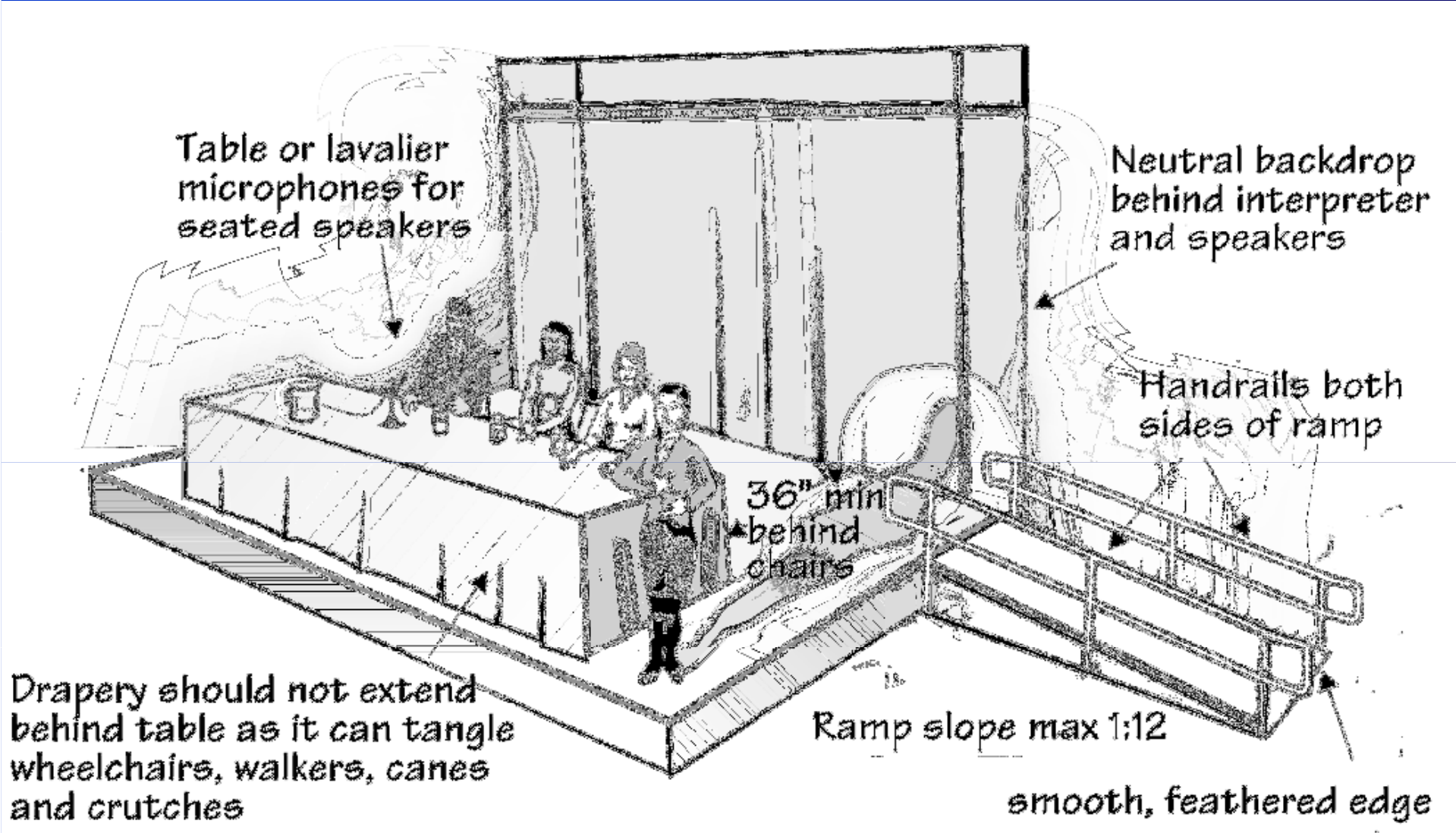

Speakers platform with interpreter

TTY

For incoming and outgoing calls

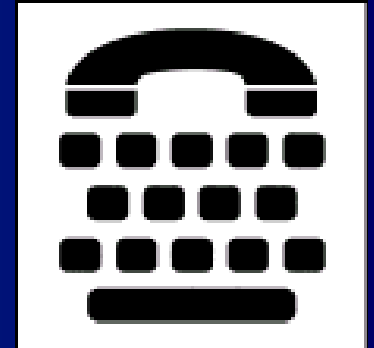

TTY

For incoming calls

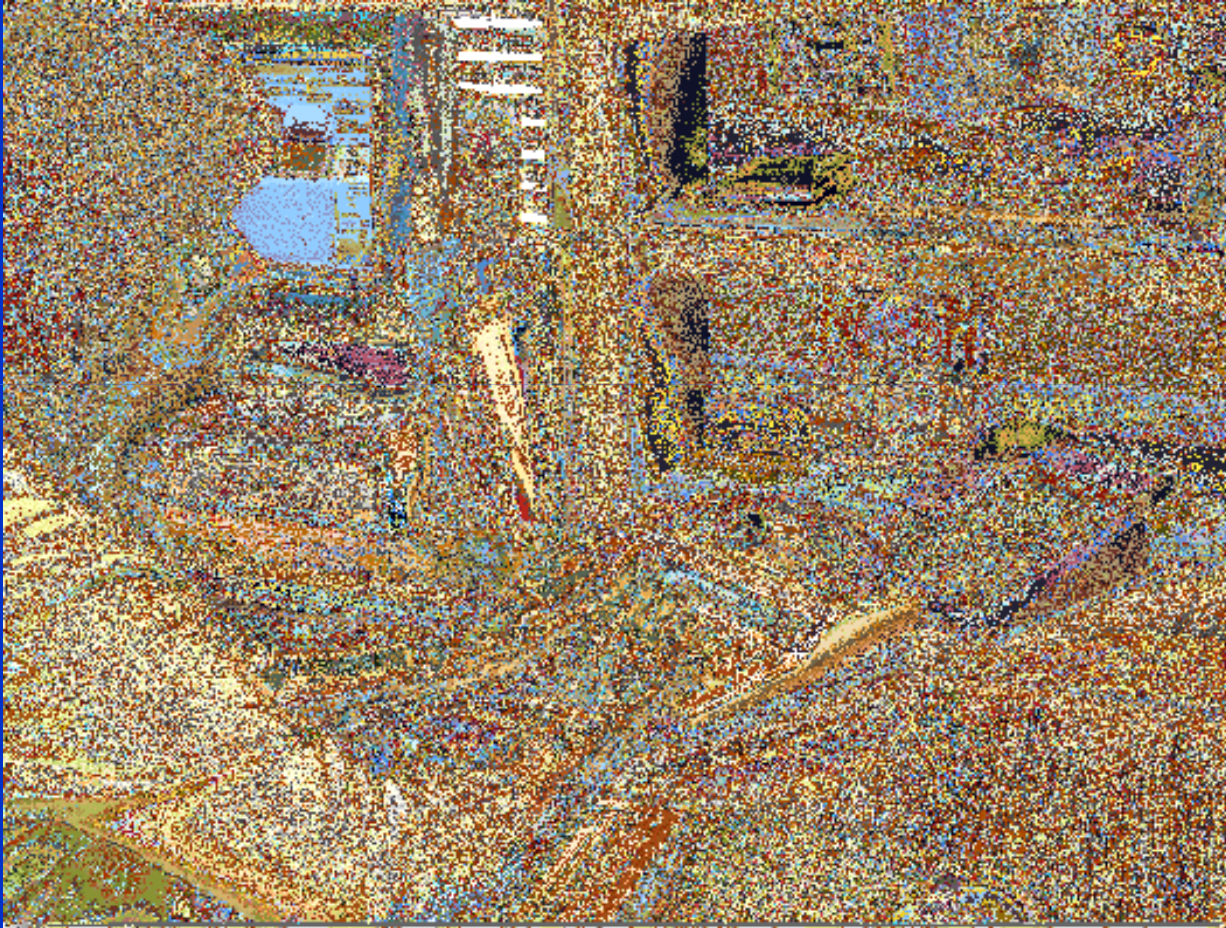

TTY For outgoing calls



From the Department of Justice's ADA Business BRIEF:
Communicating with Deaf or Hard of Hearing People in Hospital Settings

TTY Users and Relay



TTY Relay
number
711

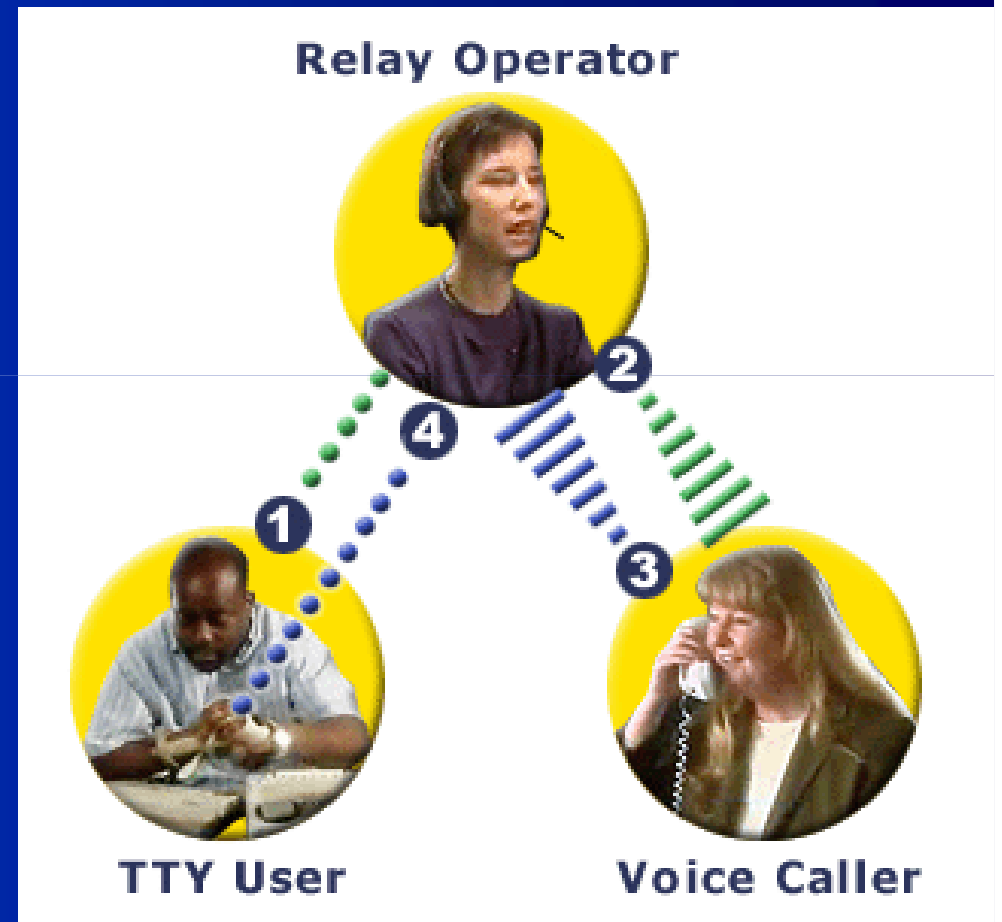

Sign Language Video Relay Service



XYZ Agency provides a variety of services including emergency shelters, transitional housing and support groups. Ms. C calls from a pay phone and asks the person answering the phone to mail information in Braille about all the agency's services to her neighbor's house.

The person answering the phone:

1. Makes arrangements for the info to be Brailled (where??)
2. Tells her supervisor
3. Tells the ADA coordinator
4. Other

Auxiliary Aids and Services For People Who are Blind/Have Low Vision

- Braille
- Email files
- Computer disks, thumb drive
- Qualified readers
- Audio recordings
- Large Print (what size font?)

Web Accessibility

City of Fullerton Official Web Site -- City of Fullerton, CA
http://www.ci.fullerton.ca.us/

Official Web Site of the City of Fullerton

Search
The whole city site is

What's New | FAQs | City Facts | Links | Help | Home

303 W. Commonwealth, Fullerton, CA 92832 * (714) 738-6317
Hours: 7:00 to 5:30 Mon-Thru, 7:30 to 5:00 Friday, Closed alternate Fridays

Disclaimer
The material provided here is designed to help you become better acquainted with Fullerton and the services it has to offer, as well as assist you in obtaining the information you need to live, work, conduct business, and have fun in our community.

City Hall Hours of Operation
City Council
Agendas & Minutes
Job Opportunities
Municipal Code
Classes & Excursions
Downtown Fullerton
Press Releases
Community Calendar
"Focus on Fullerton"
Library Catalog and Patron Information
Recycling Programs

Departments:
Administrative Services
Airport
City Clerk
City Manager
Community Services
Development Services
Engineering
Fire
Library

Welcome to Downtown

Located 22 miles southeast of metropolitan Los Angeles, in the center of North Orange County, Fullerton is a full-service city renowned for its unique mix of residential, commercial and industrial, educational, and cultural environments which provide an outstanding quality of life for both residents and businesses alike. Fullerton, one of the largest cities in Orange County, is a community with a strong sense of tradition, one that treasures its historic past as it prepares to meet the challenges of its future.

We hope you will find our web site helpful. We will be updating it regularly, adding more to it in the future. If you would like further information about the City or this home page, please call the Fullerton Public Information Office at (714) 738-6317.

Emergency Preparedness
A Guide to Domestic Preparedness
For more emergency preparedness information, please check the Department of Homeland Security website at www.dhs.gov

Special Events:
[Fullerton Memorial Day Observance](#)
[Fullerton Railroad Days](#)
[Fullerton Market Returns](#)
Other events

Auxiliary Aids and Services For People Who Have Speech Disabilities

- **TTYs**
- **Computers**
- **Speech synthesizers**
- **Communication boards**

Speech Synthesizer



Communication Board

EZ PICTURE BOARD BY VIDATAK
AN INNOVATION IN PATIENT COMMUNICATION

● I AM

short of breath 	in pain 	choking 	feeling sick
hungry/thirsty 	cold/hot 	tired 	dizzy
angry 	afraid 	frustrated 	sad

● I WANT

to be suctioned 	lip moistened 	water 	to be comforted 	to sleep
tv/video/dvd 	call light /remote 	it quiet 	lights off/on 	to go home
to sit up 	to lie down 	to turn left/right 	head of bed up/down 	get out of bed

● I WANT TO SEE

doctor 	nurse 	family 	chaplain
------------	-----------	------------	--------------

no 	yes 	
--------	---------	--

A	B	C	D	E	F	G	H	I	1	2	3	Thank You
J	K	L	M	N	O	P	Q	R	4	5	6	
S	T	U	V	W	X	Y	Z	.	7	8	9	I Love You
'	,	?	!	SPACE					+	0	-	

For infection control purposes, please do not reuse this board between patients.

When providing an auxiliary aid or service, your organization is required to provide what the person wants no matter how much it costs.

True or False?

Undue Burden

If the auxiliary aid or service is necessary to ensure equally effective communication

Provide unless it would be an undue financial and administrative burden

ADA & Section 504

- ✓ **General nondiscrimination**
- ✓ **Effective communication**

Facility access

Employment

Facility Accessibility



New construction and alterations must be accessible

ADA Standards for Accessible Design
July 1, 1994 (that's not a typo!)

New Construction and Alterations

**ADA Standards for Accessible Design
July 1, 1994 (that's not a typo!)**

**Department of Justice to adopt US
Access Board's 2004 ADA Accessibility
Guidelines**

What About Equipment?

Ms. M has quadriplegia and uses a power wheelchair. She has been raped She is at the clinic for a sexual assault exam.

The exam table is at a fixed height and Ms. M is unable to transfer onto the table.

Does the ADA require that your clinic have an adjustable height table?

“Existing” Facilities



How much accessibility is required in older buildings?

Existing Facilities

Two different requirements

ADA Title II & Section 504

Program accessibility

ADA Title III

Readily achievable barrier removal

ADA Title II & Section 504 Existing Facilities

Program accessibility:

Ensure that each program, service and activity, when viewed in its entirety, is accessible to people with disabilities

ADA Title II & Section 504 Program Accessibility Methods

- Reassignment to accessible site
- Home visits
- Assignment of aides (human)
- Make structural changes

Goal: Most integrated setting appropriate

What method is appropriate for your program?

ADA Title III

Existing Facilities

Readily Achievable Barrier Removal

Make access improvements that are
“readily achievable”

Easily accomplishable and able to be
carried out without much difficulty or
expense

ADA Title III

Readily Achievable Barrier Removal

Priorities

1. Getting in
2. Getting to the goods and services
3. Restroom
4. Other amenities (public telephones, water fountains, alarms, etc.)

ADA Title III

Readily Achievable Barrier Removal

- Landlords and tenants have barrier removal obligations
- Tax credits/deductions are available
- On-going obligation

Getting in, Getting to



Accessible Route



Stable

Firm

Slip resistant

36" min width



Accessible Entrance New Construction, No Ramp



Accessible Entrance Old Building, Stairs & Ramp



If not all entrances are accessible...

- Signs at inaccessible entrances



Interior Circulation

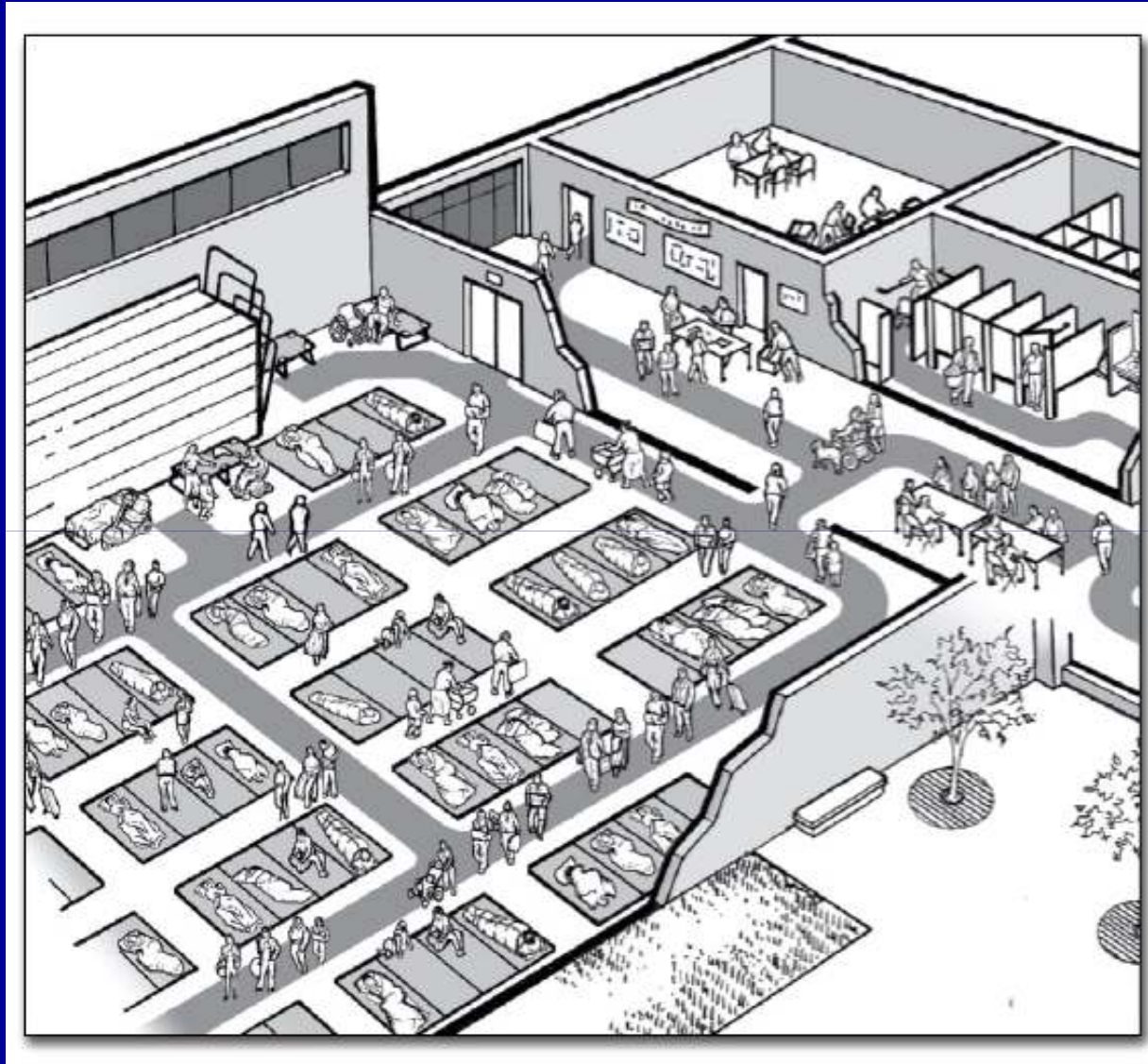

From the Department of Justice's Guide for Emergency Shelters

Adaptive Environments

Interior Circulation Vertical Access

Independently operable



Accessible Restrooms



Protruding Objects

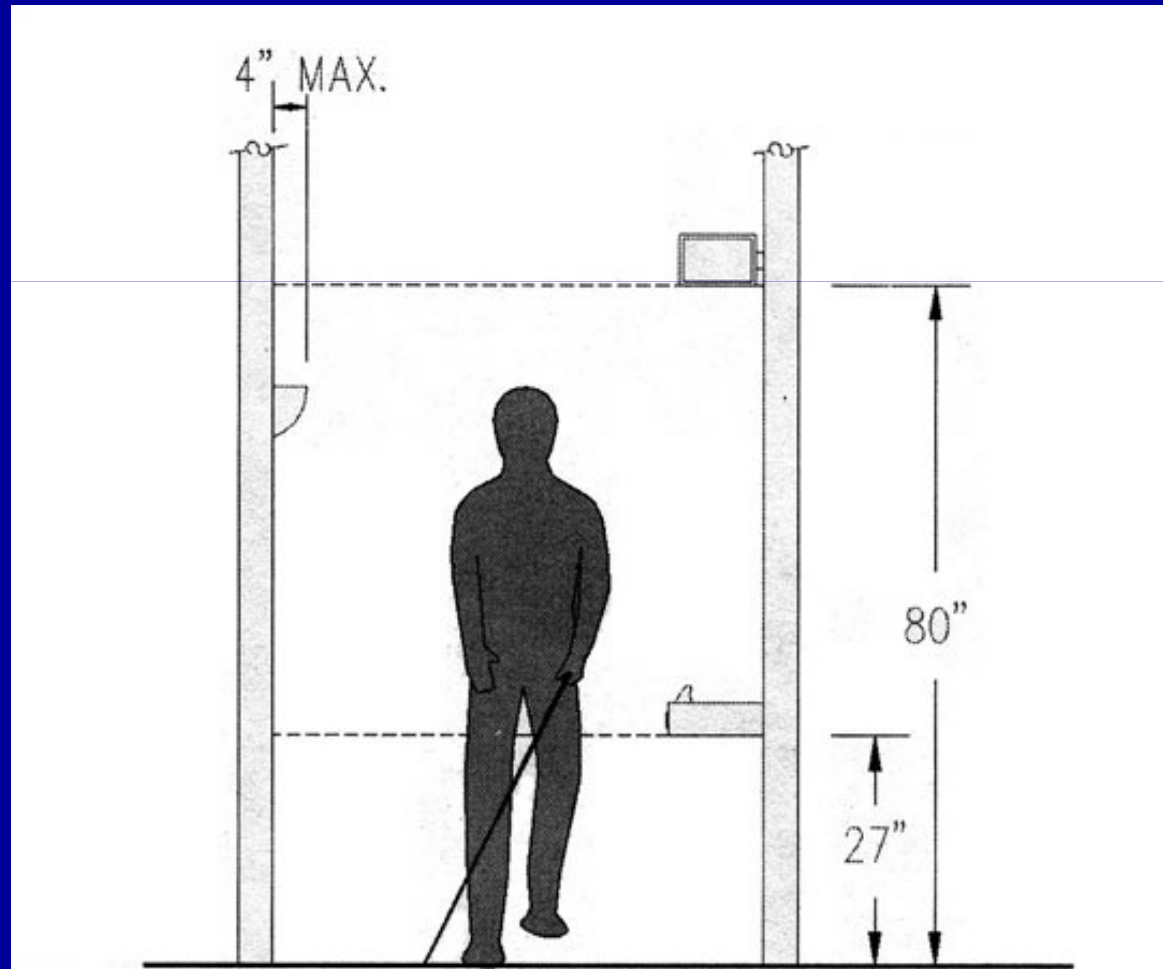

Visual Alarms Consider Locations



Maintenance of Accessible Features

Maintain in operable working condition those features of facilities and equipment that are required to be readily accessible



ADA & Section 504

- ✓ **General nondiscrimination**
- ✓ **Effective communication**
- ✓ **Facility access**

Employment

Ms. A has worked at ABC Agency for five years. She has cerebral palsy. During the past year she started using a cane. Ms A tell her supervisor Ms. Z that walking back and forth to the printer er has become difficult and requests that her desk be moved closer to the copier. Ms. Z tells Ms. A that she must put her request in writing and provide medical documentation that she has a disability, has difficulty walking and needs her desk closer to the copier. After receiving those items Ms. Z holds a staff meeting, explains Ms. A's difficulty and asks people who work close to the printer if anyone is willing to switch places. No one volunteers. Ms Z goes to you, the human resource person to discuss the situation.

ADA & Section 504 Employment

Does person have an ADA disability?

Is this a request for reasonable accommodation?

May employer require request be in writing?

Under what circumstances may an employer require medical documentation?

What about confidentiality?

What are employee's essential job functions?

RA discussion is supposed to be an informal interactive process.

ADA & Section 504

Reasonable Accommodation

- Any change in the work environment or in the way things are usually done that results in equal employment opportunity for an individual with a disability
- Provide if needed, unless undue hardship

Graphic Artists Guild Access Symbols

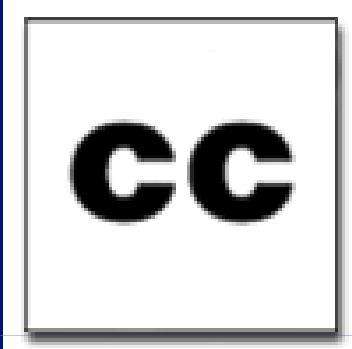
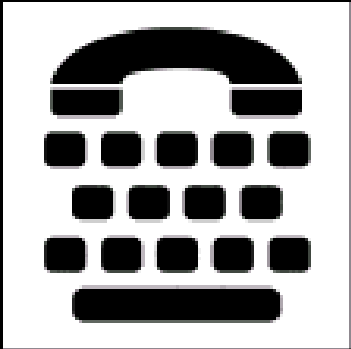

Questions, Discussion